

# Monitoring Maize Irrigation System Using Arm Microcontroller LPC2148

T. Gayathri<sup>1</sup>, R. Boomidevi<sup>2</sup>, S. Ragul<sup>3</sup>

PG Scholar, Dept of EEE, Kongunadu College of Engineering and Technology, Trichy, Tamilnadu, India<sup>1,2</sup>

Assistant Professor, Dept of EEE, Kongunadu College of Engineering and Technology, Trichy, Tamilnadu, India<sup>3</sup>

**Abstract:** In this paper, the system is designed for monitoring the growing status of the Maize plant continuously and updates the information to the agriculturist using ARM Microcontroller LPC2148. This project will make ease the work of the farmer in cultivated land through the usage of different kind of sensors. The temperature sensor LM35 will find the intensity of heat present in the soil. Humidity sensor will determine the amount of water vapor present in a gas that can be a mixture, such as air, or a pure gas, such as nitrogen or argon. Water level sensor will find the water level in the corn field. The PH sensor will measure the alkalinity or acidity level in the soil. Soil pH is very important because it has such a strong influence on how well your crops will grow. Soil Moisture sensor can be used to test the moisture of soil, when the soil is having water shortage, the module output is at high level; else the output is at low level. By using this sensor one can automatically water the Maize plant by switching ON the DC Motor. All the updates of farmland are sending to the farmer through GSM and display in the LCD screen. With this less cost and energy utilization, WSN is a hopeful method for harvesting the Maize crop and also improves the quality of the corn crop and reduces the usage of pesticides, thereby increasing the overall profits for the farmers.

**Keywords:** ARM Microcontroller, Wireless Sensor Network (WSN), GSM, Sensors, DC Motor etc.

## I. INTRODUCTION

Today, Agriculture plays very important role in country development. To make feasible for the farmer, the automatic monitoring system for maize farmland using different sensors, ARM Microcontroller etc., and transmit the farm information through SMS to the farmer using Global Positioning System (GPS). Wireless Sensor Network plays important task in monitoring physical, environmental conditions used in the agricultural field, military surveillance, industrial, consumer application, etc., In the agriculture field, wireless sensor network is used to monitor Temperature, Humidity, Soil moisture, Wind, Pressure, PH and Redox. By monitoring the corn growth continuously will achieve better yield with less manpower.

If the canopy growth reaches its threshold value, then the information was displayed in the Liquid Crystal Display (LCD) and also send to the cultivator through mobile phone SMS for monitoring the canopy growth using LDR sensor with GSM [1]. Using wireless sensor network (WSN), the Leaf Area Index (LAI) was monitored continuously for measuring plant growth in forest by LAInet method and the information are shared using cloud computing [2].

The automatic irrigation system will save all the unique stages of plant growth and the message about plant growth are transferred through Zigbee module to the agriculturist [3]. Using Digital Image Processing, the unique stages of plant growth are taken as input image. Based on the captured image with its weather condition, the nutrition

material is given to the plant for its better yield [4]. The INTELLIGENT HUMIDITY sensor will automatically monitor the soil moisture level in the farmland with reduced power consumption by collecting only less data which in turn cause more data to be lost in the system and there is no need to monitor and save the bulky data required in agricultural fields [5].

The different types of crops such as Paddy, banana, turmeric fields the canopy growth was monitored by a temperature sensor, humidity sensor, soil moisture sensor and the information about the farm are transmitted using a Zigbee module to the farmer and consume less power by using solar cells [6]. Using the Image Processing, the population of the corn plant count is measured automatically using a digital video camera on the vehicle moving in the distance of 1 to 2m/s. Based on this count, the fertilizers are given to the plant more approximately with avoiding insect attack [7].

In the proposed system, the Maize plant is continuously monitored by Temperature sensor, Humidity sensor, Water level sensor, PH sensor and finally the Soil Moisture sensor automatically and updates the information about crop growth to the agriculturist periodically through mobile phone SMS using Global Positioning System (GPS) for improving the quality of the maize with better yield by avoiding spraying of chemical substance in the farmland which in turn reduces the insect attack in the corn.

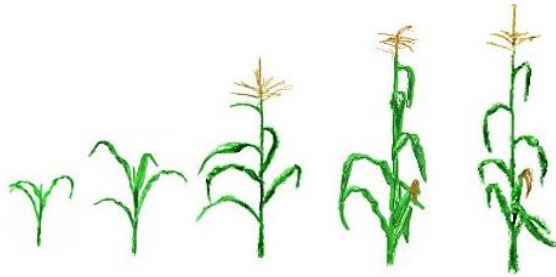
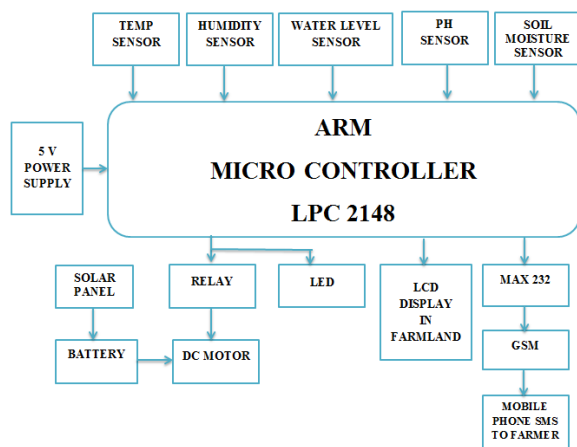

**Fig -1: Stages of Corn Plant Growth**

The power consumption is reduced by using Solar cell panel for running stepper motor automatically when the water level becomes low in the farmland and switch off the motor after watering the field with glowing LED. By using ARM Microcontroller LPC2148, the sensor will sense the temperature of the soil, soil moisture level, water level in the field, the humidity level in air, the amount of acidity in the soil and display the messages on the LCD screen and also update the details to the farmer by connecting GSM using max232 in UART module. The system will make feasible for agriculturist in the modern environment.

### 2. SYSTEM ARCHITECTURE

The Architectural model is developed to monitor the corn growth in the farm. The ARM Microcontroller LPC2148 is a low cost RISC processor with multiple features. When the 3.3v power supply is given to the ARM Microcontroller LPC2148 microcontroller, the sensors which are attached to the controller start sensing the maize farmland.



**Fig -2: Block Diagram for Monitoring Corn Growth**

The Temperature sensor will perceives the soil temperature in the corn field. If the temperature is high, then intimate to the cultivator through mobile phone SMS via GSM. The humidity sensor will sense the air moisture level. The Soil Moisture sensor will find the soil moisture level, if it low then it automatically turn ON the DC motor. The DC motor will run on battery supply from the solar

cell panel and LED will also glow when the DC motor runs. The water level sensor will sense the water level in the farm aloft or not, if it exceeds then automatically switch OFF the DC motor.

The solar cell arrangement is designed based on the amount of power required to run the DC motor The PH sensor will identify the alkalinity of the soil caused by the chemical substance applied in the farmland. The LCD display will shows the messages about corn grown in cultivated land. The max232 is used to connect the GSM to the ARM Microcontroller LPC2148 in UART module. The mobile phone SIM should be registered for sending messages to the cultivator. By using the messages displayed on the cultivator’s phone, the corn field situation will periodically know. If any upsurge changes occur, it will inform the cultivator.

### 3. COMPONENTS REQUIRED

#### 3.1 Microcontroller:

The ARM (Advanced RISC Machine) microcontroller is based on Harvard architecture with RISC processor developed by Philips (NXP) The ARM Microcontroller LPC2148 is a one of the most powerful controller which has 32 bit instruction set. The high performance ARM Microcontroller LPC2148 executes the instruction in very high speed within less cost.

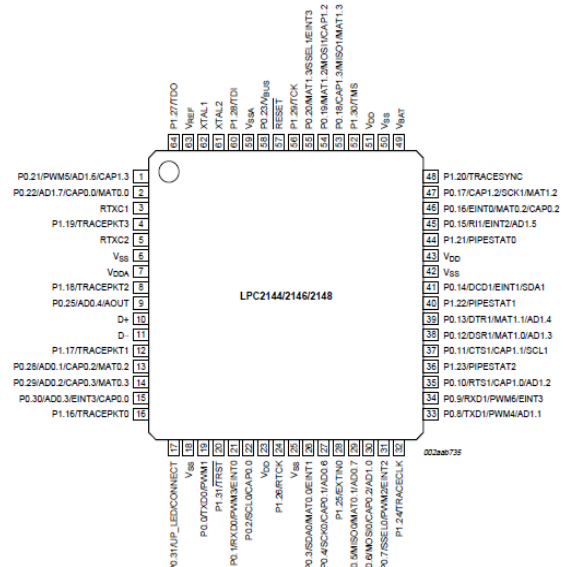

**Fig -3: ARM Microcontroller LPC2148 Pin Diagram**

It is reliable and easy to interface with its peripherals. The power required for operating ARM Microcontroller LPC2148 is less than 3.3V power supply.

#### 3.2 Temperature Sensor:

The Temperature sensor LM35 is used to find the temperature of the corn field. For corn plant the temperature should be little high. Normally corn crop are planted in summer season in our country. The LM35 is

low cost and locally accessible sensor. But for low power consuming, the THERM200 is also another choice for measuring temperature of soil in corn field. The temperature will hold the ranges between 24<sup>o</sup> to 35<sup>o</sup>. The LM35 will measure the temperature in the corn farmland.



Fig -4: Temperature Sensor LM35

**3.3 Humidity Sensor:**

The humidity sensor will find the water content in the air responsible for the soil moisture. In the corn farmland, Humidity sensor determines the amount of water vapour present in a gas that can be a mixture, such as air, or a pure gas, such as nitrogen or argon. Most commonly used units for humidity measurement are Relative Humidity (RH), Dew/Frost point (D/F PT) and Parts per Million (PPM). RH is a function of temperature, and thus it is a relative measurement. Dew/Frost point is a function of the pressure of the gas but is independent of temperature and is therefore defined as absolute humidity measurement. PPM is also an absolute measurement.

**3.4 Water Level Sensor:**

The water level sensor will find the water content level in the corn farmland. If the water level is low or high by using the DC motor the water is supplied to the field using solar power supply. Level sensors detect the level of water flow in the field, including liquids, slurries, granular materials, powders etc., Fluids and fluidized solids flow to become essentially horizontal in their farm land or other physical boundaries because of gravity whereas most bulk solids pile at an angle of repose to a peak.

**3.5 Soil Moisture Sensor:**

Soil Moisture sensor will find the moisture level in the soil. In the Maize field, the soil moisture probes can be permanently installed at representative points in an agricultural field to provide repeated moisture readings over time that can be used for irrigation management.



Fig -5: Soil Moisture Sensor

Soil moisture content may be determined via its effect on dielectric constant by measuring the capacitance between two electrodes implanted in the soil.

**3.6 PH Sensor:**

The PH sensor is very useful in the corn field to find the alkalinity in the natural or chemical materials present in the soil. The PH of the soil is responsible for its nutrition content. By knowing the PH of the soil, the minerals are sprayed in the corn field without affecting the corn quality.

**3.7 DC Motor:**

The DC motor is used to watering the corn farm. The DC motor converts electrical energy into the mechanical energy. Here, the DC motor operates based on the commands from the humidity sensor and water level sensor in the corn farmland. The speed of the DC motor is maintained by voltage applied to it.

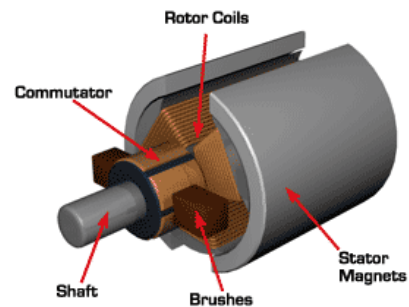

Fig -6: DC Motor

The Relay will act as a switch for operating DC motor in ON or OFF condition for supplying the water to the corn field. The Relay has the coil, when the current is flowing in the coil; it creates the magnetic field and attracts the lever, which in turn causes the switch ON or OFF state.

**3.8 LCD Display:**

The Liquid Crystal Display (LCD) is used to display the messages of the corn farmland which has been interfaced with the ARM Microcontroller LPC2148.



Fig -7: LCD Display

**3.9 GSM:**

GSM (Global System for Mobile communication) is the 2<sup>nd</sup> Generation mobile phone. GSM SIM will send the information about the farmland situation to the farmer through max232 module. It is advanced technology than GPRS, RF module, Zigbee etc. Using RS232 cable, the GSM module has communicated with the controller as serial communication. The voltage level varies from -15v to +15v for showing output signal.

## 4. SOFTWARE DESCRIPTION

### 4.1 PROTEUS:

PROTEUS is Processor for Text Easy to Use simulation tool for embedded microcontroller. The main features are being fully functional and procedural programming function. It has clear and comprehensible syntax. PROTEUS is easy to use, efficient, complete, and readable. C/C++ language is mostly used in the PROTEUS software. The advantages of PROTEUS is powerful string manipulation, comprehensibility of Proteus scripts, availability of arrays, AVL trees etc. In this paper PROTEOUS 8 version is used.

### 4.2 MPLAB IDE:

MPLAB IDE is the integrated development environment. The MPLAB IDE software runs the program on the windows operating system. It is used for developing the application for microchip microcontrollers and digital signal controllers. MPLAB provides a single integrated 'environment' is used to develop the code for embedded microcontroller. So it is called as an The features of MPLAB are comprehensive editor, project manager and design desktop. It is used for application development of embedded designs using Microchip PIC MCUs and ds PIC DSCs. The HI-TECH C compiler is used to build the embedded c coding in the MPLAB software.

## 5. HARDWARE PROGRAMMING DESCRIPTION

### 5.1 KEIL IDE:

Integrated development environment popularly known as IDE is a suite of software tools that facilitates microcontroller programming. The Keil IDE enables the embedded professional to develop the program in C and assembly as well. The IDE passes through the source code to check the syntax. The compilation leads to a hex file to be dumped in the microcontroller on-chip ROM. A quick session of simulation and debugging using the IDE ensures the working of the program beforehand.

The user can verify the results as the package presents screenshots of on-chip resources. It is recommended that while going through the discussion the user should access the  $\mu$ Vision 2 package of the Keil. A step-by-step working as discussed in this chapter will empower the user to get familiar with the Keil IDE.

### 5.2 Orcad:

Orcad is a proprietary software tool suite used primarily for electronic design automation. The software is used mainly to create electronic prints for manufacturing of printed circuit boards, by electronic design engineers and electronic technicians to manufacture electronic schematics and diagrams, and for their simulation. The name Orcad is a portmanteau, reflecting the software's origins: Oregon + CAD. The Orcad product line is fully owned by Cadence Design Systems. The latest iteration has the ability to maintain database of available integrated circuits. This database may be updated by the user by downloading packages from component manufacturers, such as Analog Devices or Texas Instruments.

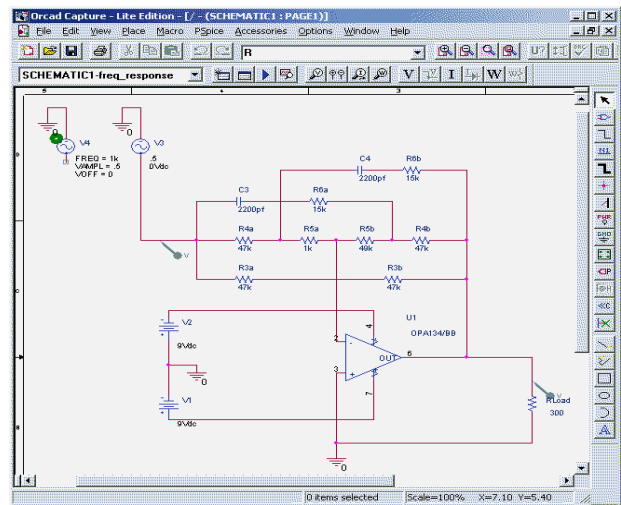

**Fig: -9** Orcad

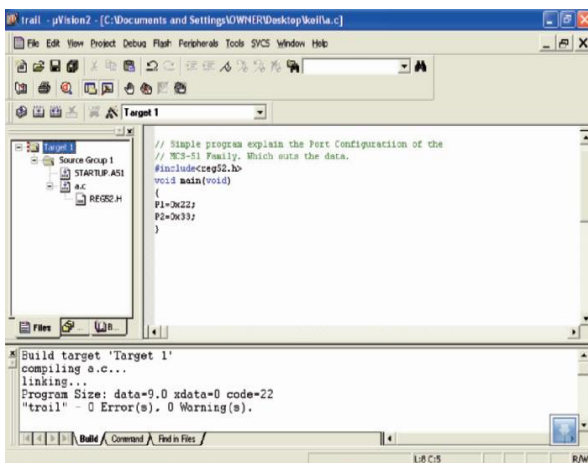

**Fig: -8** KEIL IDE

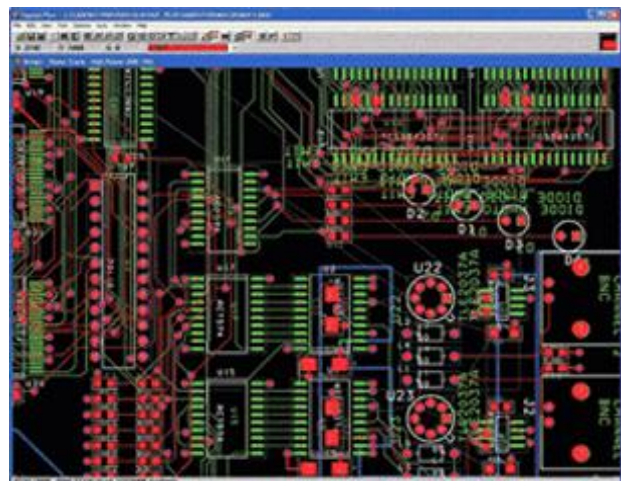

**Fig: -10** Layouts

5.3 Flash Programmer:

- Straightforward and intuitive user interface
- Five simple steps to erasing and programming a device and setting any options desired
- Programs Intel Hex Files
- Automatic verifying after programming
- Fills unused Flash to increase firmware security
- Ability to automatically program checksums. Using the supplied checksum calculation routine your firmware can easily verify the integrity of a Flash block, ensuring no unauthorized or corrupted code can ever be executed
- Program security bits
- Check which Flash blocks are blank or in use with the ability to easily erase all blocks in use

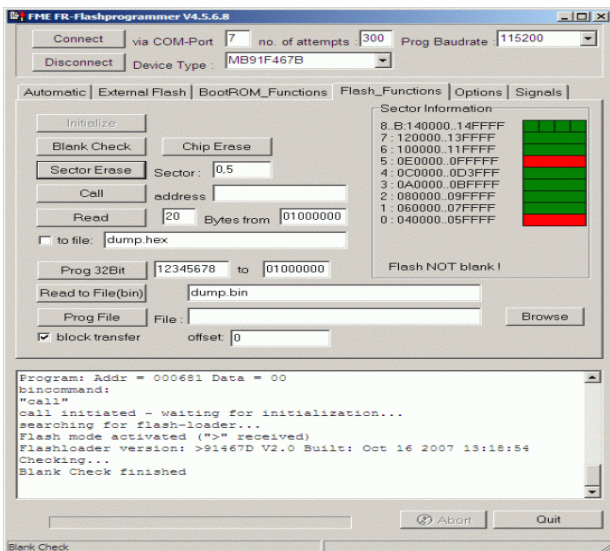

Fig: -11 Flash Programmer

5.4 Embedded C:

The C for microcontrollers and the standard C syntax and semantics are slightly different. The former is aimed at the general purpose programming paradigm whereas the latter is for a specific target microcontroller such as ARM. The underlying fact is that everything will be ultimately mapped into the microcontroller machine code. If a certain feature such as indirect access to I/O registers is inhibited in the target microcontroller, the compiler will also restrict the same at higher level. Similarly some C operators which are meant for general purpose computing are also not available with the C for microcontrollers. Even the operators and constructs which may lead to memory inefficiency are not available in C programming meant for microcontrollers.

6. SIMULATION OUTPUT

The Proteus output for corn plant farmland monitoring system is shown below. Fig -12 schematic will display monitoring status in the LCD screen.

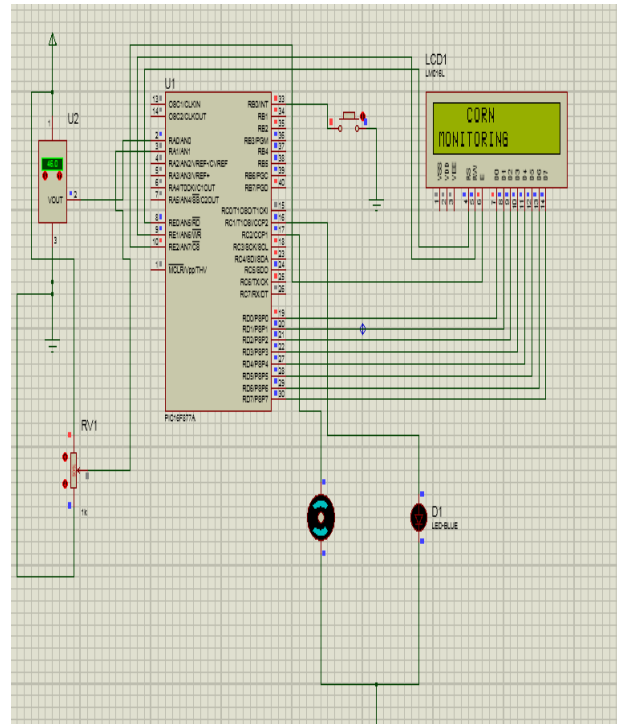

Fig -12: Schematic output screen1

The water level in the farmland is detected by water level sensor and humidity sensor. If the water level is low, the DC motor is starts running with the help of solar power supply. The Fig -13 will show the schematic output for running DC motor during less water level in the farmland.

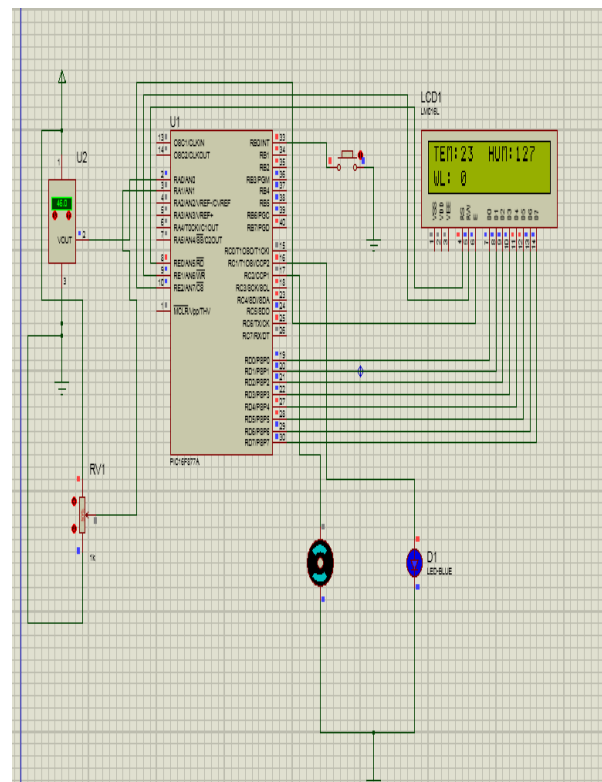

Fig -13: Schematic output screen2



## 7. CONCLUSION

The project had resulted as efficient monitoring system for the maize farmland and informs the details about the current situation of the farm to the cultivator by using different sensors. By using solar power source, the power consumption cost required for driving the processor and DC motor is reduced.

## REFERENCES

- [1] P.S.Sathish, B.Chellaprabha “Monitoring the Plant Growth Using Sensor Network” ARPN Journal of Engineering and Applied Science VOL 10, NO 7, APRIL 2015 ISSN 1819-6608
- [2] A. Ahamed Meeran, Mydeen, A. Balasubramanian, V. Mahalakshmi, P. K. Dhal, “Observation and Cloud Storage of Crop Leaf Area Index Using Wireless Sensor Network” International Journal of Emerging Technology and Advanced Engineering (ISSN 2250-2459, ISO 9001:2008 Certified Journal, Volume 5, Issue 4, April 2015)
- [3] Patil Kalika Milind, P.C.Bhaskar, “Microcontroller Based Adaptive Irrigation System Using WSN for Variety Crops and Development of Insect Avoidance System for Better Yield” IJRET: International Journal of Research in Engineering and Technology eISSN: 2319-1163 | pISSN: 2321-7308 Volume: 03 Issue: 07 | Jul-2014
- [4] Anil Kakran Rita Mahajan, “Monitoring Growth of Wheat Crop Using Digital Image Processing” International Journal of Computer Applications (0975 –8887) Volume 50 –No.10, July 2012
- [5] Kshitij Shinghal, Dr. Arti Noor, Dr. Neelam Srivastava, Dr. Raghuvir Singh, “Intelligent Humidity Sensor For - Wireless Sensor Network Agricultural Application” International Journal of Wireless & Mobile Networks (IJWMN) Vol. 3, No. 1, February 2011
- [6] Dr. K. Srinivasa Ravi, K.Tapaswi, B.Lokesh, G.Sai Krishna, “Smart Sensor System for Agricultural Chronology” K. Srinivasa Ravi et al / (IJCSIT) International Journal of Computer Science and Information Technologies, Vol. 2 (6) , 2011, 2650-2658.
- [7] D. S. Shrestha, B. L. Steward, “Automatic Corn Plant Population Measurement Using Machine Vision” Vol. 46(2): 559–565 Transactions of the ASAE E 2003 American Society of Agricultural Engineers ISSN 0001–2351 ASAE in December 2002

## BIOGRAPHIES



**T. Gayathri** was born in Trichy, Tamilnadu, India on 15-11-1992. She received the bachelor degree in electronics and communication engineering from the Agni College of Technology, Chennai, Tamilnadu, India, in 2014. She is now doing M.E., degree in Embedded System Technologies from Kongunadu College of Engineering and Technology, Trichy, Tamilnadu, India.



**R. Boomidevi** was born in Chennai, Tamilnadu, India on 30-07-1989. She received the bachelor degree in electronics and communication engineering from the Veltech Hightech engineering College, Chennai, Tamilnadu, India, in 2014. She is now doing M.E., degree in Embedded System Technologies from Kongunadu College of Engineering and Technology, Trichy, Tamilnadu, India.



**S. Ragul** was born in Namakkal, Tamilnadu, India on 14-04-1988. He received the M.E., degree in power electronics and drives from Anna University, Chennai, Tamilnadu, India, in 2012, respectively. He is now working as an Assistant Professor in the department of Electrical and Electronics Engineering at Kongunadu College of Engineering and Technology, Trichy. He is published his research work in various National/ International journals and Conference. His teaching and research areas include Electrical Machines, Fault Diagnosis, Intelligent Techniques, Power Electronics and Drives and Machine Design. Mr. Ragul is a member of IEEE.